

**LS 763**

**Protective throughbeam photoelectric sensor**

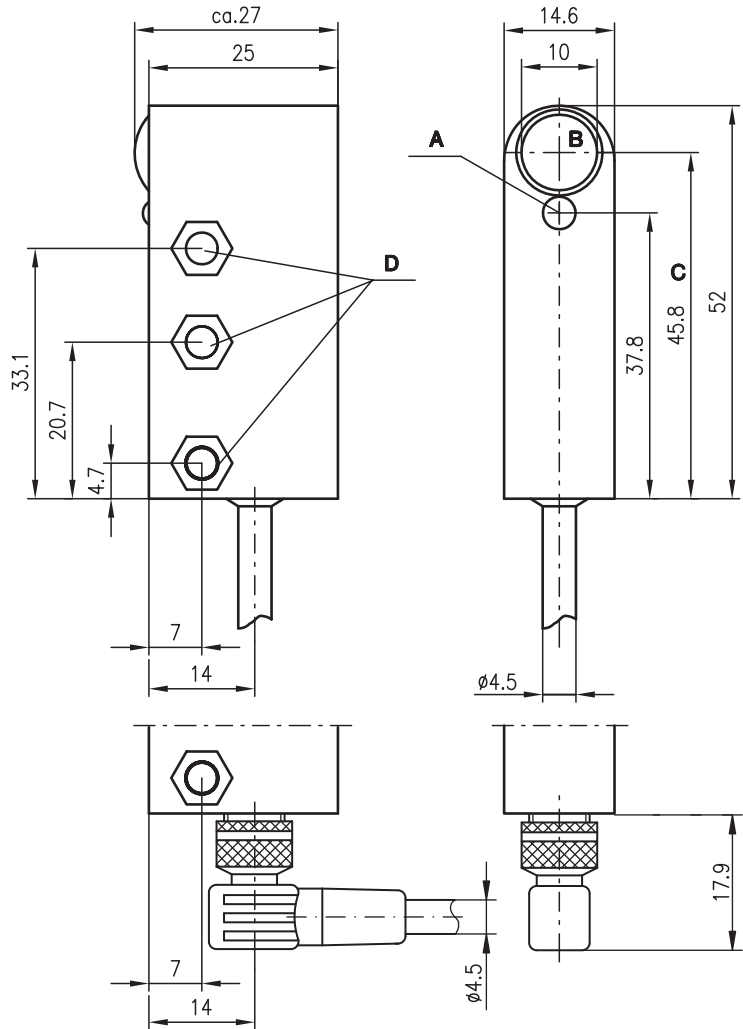

**Dimensioned drawing**



- A** Indicator diode
- B** Transmitter/receiver
- C** Optical axis
- D** M4 flat nut for inserting

**Electrical connection**

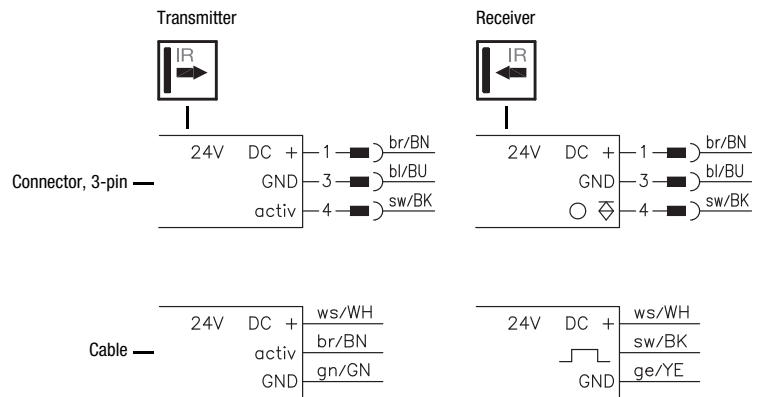

en 06-2016/02 602033-03

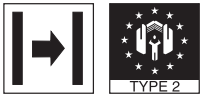

**8m**



- Protective throughbeam photoelectric sensor with high performance reserve in infrared light, up to PL c, category 2 in accordance with ISO 13849-1
- Activation input for testing and interlinking of the sensor
- Compact construction with shock-resistant metal housing and glass optics
- LED indicator for function monitoring in transmitter and receiver
- PNP transistor output for PLC applications
- Connection via M8 connector or flexible PUR connection cable



**Accessories:**

(available separately)

- Mounting system (BT 763)
- M8 connectors (D M8A-3P-SK)
- Ready-made cables (K-D ...)
- Test monitoring units
  - MSI-TR1B-01 (Part No. 547958)
  - MSI-TR1B-02 (Part No. 547959)
- Sensorscope SAT 5 (alignment control, Part No. 50109545)

We reserve the right to make changes • DS\_LS763\_Standard\_en\_602033\_03.fm

## Specifications

### Safety-relevant data

Type in accordance with IEC/EN 61496	type 2
Performance Level (PL) in accordance with ISO 13849-1 <sup>1)</sup>	PL c
Category in accordance with ISO 13849 <sup>1)</sup>	cat. 2
Mean time to dangerous failure (MTTFd)	300 years
Service life (TM)	20 years

### Optical data

Typ. operating range limit <sup>2)</sup>	0 ... 8m
Operating range <sup>3)</sup>	0 ... 6m
Light source	LED (modulated light)
Wavelength	880nm
Optics diameter	10mm
Darkening object	8mm
Effective angle of radiation	max. ± 4° in accordance with EN IEC 61496/-1-2

### Timing

Switching frequency	100Hz
Response time	min. 5ms

### Electrical data

Operating voltage $U_B$ <sup>4)</sup>	24 V DC ± 15 %
Residual ripple	≤ 10% of $U_B$ (tip/tip)
Open-circuit current	receiver ≤ 15 mA transmitter ≤ 20 mA
Safety class	III
Switching output	PNP transistor output
Function	light switching
Signal voltage high/low	≥ ( $U_B - 2V$ ) / ≤ 2V
Output current	max. 100mA

### Indicators

<b>Transmitter</b>	
Yellow LED	transmitter active
<b>Receiver</b>	
Red LED	light path interrupted
Green LED	light path free

### Mechanical data

Housing	diecast zinc, electroplated
Optics	mineral glass
Weight	130g
Connection type	M8 connector or cable, PUR, 2.5m length

### Environmental data

Ambient temp. (operation/storage)	-20°C ... +60°C / -30°C ... +70°C
Protective circuit <sup>5)</sup>	2, 3
Protection class	IP 65
Standards applied	IEC 90647-5-2

### Options

<b>Activation input</b> active	
Transmitter active/not active	≥ 20V / ≤ 2V or not connected
Activation/disable delay	≤ 0.5ms
Input resistance	10kΩ ± 10%

- 1) In combination with a suitable test monitoring unit, e.g. MSI-TR1  
 2) Typ. operating range limit: max. attainable range without performance reserve  
 3) Operating range: recommended range with performance reserve  
 4) Protective extra-low voltage (VDE 0100/T 410)  
 5) 2=polarity reversal protection, 3=short circuit protection

## Tables

0	6	8
---	---	---

<input type="checkbox"/>	Operating range [m]
<input type="checkbox"/>	Typ. operating range limit [m]

## Order guide<sup>1)</sup>

	Designation	Part No.
<b>With M8 connector</b>		
Transmitter and receiver	LS 763/4.8, L8	
Transmitter	LS 763/2.8 Se, L8	50081024
Receiver	LS 763/4 E, L8	50081025
<b>With cable, 2m</b>		
Transmitter and receiver	LS 763/4.8, 2500	
Transmitter	LS 763/2.8 Se, 2500	50027465
Receiver	LS 763/4 E, 2500	50027466

1) Version 2010 A-Z

## Safety notices

Before using the safety sensor, a risk evaluation must be performed according to valid standards. For mounting, operation and tests, this document as well as all applicable national and international standards and regulations must be observed, printed out and handed to the affected personnel.

Before working with the safety sensor, completely read and observe the documents applicable to your task.

In particular, the following national and international legal regulations apply for the commissioning, technical inspections and work with safety sensors:

- Machinery directive 2006/42/EC
- Use of Work Equipment Directive
- Accident-prevention regulations and safety rules
- Other relevant standards
- Standards, e.g. ISO 13855

## Symbols



### Attention!

Warning sign – This symbol indicates possible dangers. Please pay especially close attention to these instructions!



This symbol identifies the transmitter.



This symbol identifies the receiver.

## Safety sensor area of application

The protective throughbeam photoelectric sensor is an active optoelectronic protective device only in connection with a safety-relevant control system, in which the cyclical testing of transmitter and receiver is carried out in accordance with EN 61496-1, up to category 2 and PL c in accordance with EN ISO 13849-1.



### Attention!

- The safety sensor protects persons at access points or at points of operation of machines and plants.
- The safety sensor only detects persons upon entry to the danger area; it does not detect persons who are located within the danger area. For this reason, a start-up/restart interlock is mandatory.
- No protective function without adequate safety distance.
- The power supply unit used to operate the photoelectric sensor has to be able to compensate for changes and interruptions of the supply voltage acc. to EN 61496-1.
- Also observe the safety notices in the documentation of the connected test device!
- Additional measures must be taken to ensure that the AOPD does not experience a dangerous failure due to glare from other light sources.

## Proper use

The safety sensor must only be used after it has been selected in accordance with the respectively valid instructions and relevant standards, rules and regulations regarding occupational safety and safety at work, and after it has been installed on the machine, connected, commissioned, and checked by a competent person.

## Foreseeable misuse

Any use other than that defined under the "Proper use" or which goes beyond that use is considered improper use. The user must ensure that no optical influence on the AOPD occurs through other forms of light beams, e.g. through

- wireless control devices on cranes,
- radiation from welding sparks,
- stroboscopic lights.

## Competent personnel

Prerequisites for competent personnel:

- He has a suitable technical education.
- He knows the instructions for the safety sensor and the machine.
- He has been instructed by the responsible person on the mounting and operation of the machine and of the safety sensor.

## Responsibility for safety

Manufacturer and operator must ensure that the machine and implemented safety sensor function properly and that all affected persons are adequately informed and trained.

The **manufacturer** of the machine is responsible for:

- Safe implementation of the safety sensor.
- Imparting all relevant information to the operator.
- Adhering to all regulations and directives for the safe commissioning of the machine.

The **operator** of the machine is responsible for:

- Instructing the operating personnel.
- Maintaining the safe operation of the machine.
- Adhering to all regulations and directives for occupational safety and safety at work.
- Regular testing by competent personnel.

## Safety distances



### Attention!

The protective throughbeam photoelectric sensor must be installed with the correctly calculated safety distance as well as suitable beam distances from a potentially dangerous motion: if an interruption of the light beam occurs, the danger area may only be reached once the machine has already come to a dead stop.

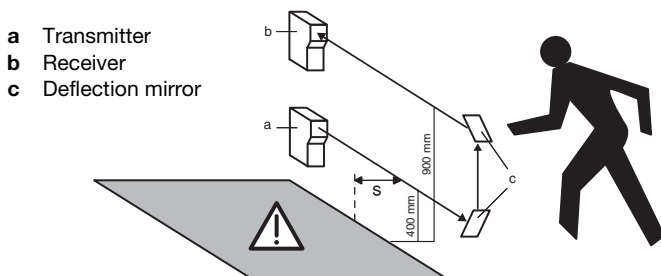

Number of beams	Heights above reference plane, e.g. floor [mm]	Additional distance C [mm]
1	750	1200
2	400, 900	850
3	300, 700, 1100	850
4	300, 600, 900, 1200	850

The safety distance **S** between photoelectric sensor and danger area is calculated using the following formula (ISO 13855):

$$S = (K \cdot T) + C$$

**S:** Safety distance [mm] between photoelectric sensor and danger area.

**K:** Approach speed (constant = 1600 mm/s).

**T:** Time delay [s] between interruption of the light beam and stand-still of the machine.

**C:** Safety constant (additional distance) = 850mm or 1200mm, see table above.

## Multi-axle installation

With multi-axle installation the light beams have to run parallel to the reference plane (e.g. floor) and must be aligned mutually parallel.

For this the beam direction must be set oppositely in each case. Otherwise the light beams could cause mutual interference and disturb proper functioning.

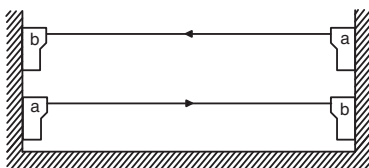

- a** Transmitter
- b** Receiver

## Distance to reflecting surfaces

When mounting, a sufficiently large distance from the optical axis to reflecting surfaces must be selected.

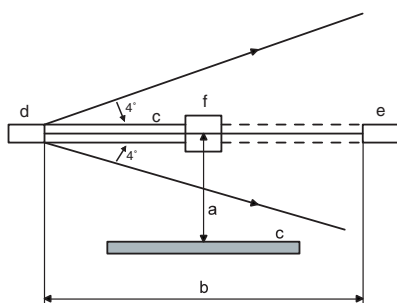

- a** Distance to the reflecting surface
- b** Protected field width
- c** Reflecting surface
- d** Transmitter
- e** Receiver
- f** Object

## Commissioning

### Alignment of the sensors

- Mount photoelectric sensors with corresponding fixing brackets from Leuze electronic.
- Apply operating voltage to transmitter and receiver and activate transmitter via activation input (see "Electrical connection").
- Yellow LED on transmitter and red LED on receiver illuminate.
- Position receiver until the green LED illuminates.

### Safety notices for test function

1. To perform testing correctly the activation input of the LS 763 transmitter must be connected to a test monitoring unit.
2. The test duration during access protection must not exceed 150ms.
3. Subsequent to sensor activation the output switching elements of the test monitoring unit must remain in the 'off' state for at least 80ms so that the downstream equipment can be switched off safely when the photoelectric sensor is used for access protection.
4. In order to comply with points 2 and 3, the use of Leuze electronic test monitoring units (MSI-TR1B-01, MSI-TR1B-02) is recommended.

## Check

The checks should ensure that the Optoelectronic Protective Devices have been used acc. to the national/international regulations, in particular in accordance with the machine and work-equipment directive.

### Check before initial commissioning

- Observe the nationally and internationally valid regulations.
- Is the required safety distance (protective field of the safety sensor to the next point of operation) maintained?
- Is the safety sensor effective during the entire dangerous movement and in all adjustable operating modes of the machine?
- It must not be possible to climb over, climb under or circumvent the light path.
- Ensure that the sensor only detects persons upon entry to the danger area and does not detect whether persons are located within the danger area.
- Is a start-up/restart interlock present?
- Before they begin work, have a competent person train the operating personnel in their respective tasks.

### Regular testing by competent personnel

The reliable interaction of safety sensor and machine must be periodically tested in order to detect changes to the machine or impermissible tampering with the safety sensor.

- Have all tests performed by competent personnel.
- Observe the nationally and internationally applicable regulations and the time periods specified therein.

### Daily check of the effectiveness of the safety sensor

It is extremely important to examine the effectiveness of the protective field daily so that it is ensured that e.g. even with adjustments to e.g. parameters, the protective function is active at all points.

Interrupt the light beam between the transmitter and receiver (test rod Ø 30mm)

- in front of the transmitter.
- in the middle between the transmitter and receiver.
- in front of and behind the deflection mirror.

It must not be possible to initiate the dangerous state during beam interruption.

## Disposal

For disposal observe the applicable national regulations regarding electronic components.



the **sensor** people

**EG-KONFORMITÄTS-  
ERKLÄRUNG**

**EC DECLARATION  
OF CONFORMITY**

**DECLARATION CE  
DE CONFORMITE**

Hersteller:

Manufacturer:

Constructeur:

**Leuze electronic GmbH + Co. KG**  
In der Braike 1, PO Box 1111  
73277 Owen, Germany

Produktbeschreibung:

**Einweg-Sicherheits-  
Lichtschranke,  
Berührungslos wirkende  
Schutzeinrichtung,  
Sicherheitsbauteil nach  
2006/42/EG  
Anhang IV  
LS763  
Seriennummer siehe  
Typenschild**

Description of product:

**Protective throughbeam  
photoelectric sensor,  
Active opto-electronic  
protective  
device,  
safety component in ace. with  
2006/42/EC annex IV  
LS763  
Serial no. see name plates**

Description de produit:

**Barrières unidirectionnelles,  
Équipement de protection  
électrosensible,  
Élément de sécurité selon  
2006/42/CE annexe IV  
LS763  
N° série voir plaques  
signalétiques**

Die alleinige Verantwortung für die Ausstellung dieser Konformitätserklärung trägt der Hersteller.

This declaration of conformity is issued under the sole responsibility of the manufacturer.

La présente déclaration de conformité est établie sous la seule responsabilité du fabricant.

Der oben beschriebene Gegenstand der Erklärung erfüllt die einschlägigen Harmonisierungsrechtsvorschriften der Union:

The object of the declaration described above is in conformity with the relevant Union harmonisation legislation:

L'objet de la déclaration décrit ci-dessus est conforme à la législation d'harmonisation de l'Union applicable:

Angewandte EG-Richtlinie(n):

**2004/108/EG (≤ 19.04.16)  
2014/30/EG (≥ 20.04.16)  
2006/42/EG**

Applied EC Directive(s):

**2004/108/EC (≤ 19.04.16)  
2014/30/EC (≥ 20.04.16)  
2006/42/EC**

Directive(s) CE appliquées:

**2004/108/CE (≤ 19.04.16)  
2014/30/CE (≥ 20.04.16)  
2006/42/CE**

Angewandte Normen:

**EN ISO 13849-1: 2008  
+ AC: 2009**

Applied standards:

**CLC/TS 61496-2: 2006**

Normes appliquées:

**EN 61496-1: 2013**

Notified Body  
TÜV NORD CERT GmbH  
Benannte Stelle: 0044  
Langemarckstr. 20  
45141 Essen / 44 205 15 159904

Dokumentationsbevollmächtigter ist der genannte Hersteller, Kontakt: [quality@leuze.de](mailto:quality@leuze.de).  
Authorized for documentation is the stated manufacturer, contact: [quality@leuze.de](mailto:quality@leuze.de).  
Autorisé pour documentation est le constructeur déclaré, contact: [quality@leuze.de](mailto:quality@leuze.de)

2014/30/EG veröffentlicht: 29.03.2014, EU-Amtsblatt Nr. L 96/79-106; 2014/30/EC published: 29.03.2014, EU-Journal No. L 96/79-106; 2014/30/CE publié: Journal EU n° L 96/79-106

*21.1.2016*

Datum / Date / Date



Ulrich Balbach, Geschäftsführer / Managing Director / Gérant

Leuze electronic GmbH + Co. KG  
In der Braike 1  
D-73277 Owen  
Telefon +49 (0) 7021 573-0  
Telefax +49 (0) 7021 573-199  
[info@leuze.de](mailto:info@leuze.de)  
[www.leuze.com](http://www.leuze.com)

Leuze electronic GmbH + Co. KG, Sitz Owen, Registergericht Stuttgart, HRA 230712  
Persönlich haftende Gesellschafterin Leuze electronic Geschäftsführungs-GmbH,  
Sitz Owen, Registergericht Stuttgart, HRB 230550  
Geschäftsführer: Ulrich Balbach  
USt-IdNr. DE 145912521 | Zollnummer 2554232  
Es gelten ausschließlich unsere aktuellen Verkaufs- und Lieferbedingungen  
Only our current Terms and Conditions of Sale and Delivery shall apply



LEO-ZQM-148-06-FO